



# Kearns PS Online Learning – Stage

Daily Lessons

# GOOD MORNING!





# Monday

Student resources



# English

Student resources

# Listen

Click here to hear instructions

[Listen to the Squiz Kids Podcast](#) - Click here

**Write a 3-2-1 response in the Google Classroom thread.**

**Write 3 things you learnt, 2 questions you have and one opinion that you have. You can respond to your classmates as well.**

**This is a compulsory task meaning that we expect a 3-2-1 response from everyone today.**

**SQUIZ  
KIDS**



# Nouns and Adjectives

In your exercise book write the definition for

- a. Noun-
- b. Adjective-

## Super Stories: The Sea Cave Game

This online activity includes clear instructions and examples to explain what nouns and adjectives are. Everything is explained in the game.

**Activity:** Practise improving noun and adjective choice by completing this writing game titled 'Super Stories: The Sea Cave'. Have fun!

[Click here for the nouns and adjectives game](#)

- a. What did you learn to do by playing the game? **Write in your exercise book.**



**Writing** - Use Google doc on GC called “Monday W5 English Activity” to complete this task

## Orientation using interesting nouns and adjectives

**Writing:** Use the picture of the haunted house on this slide as a stimulus for your writing.

Write only the **orientation** of a short story about a haunted house. Apply what you have learned by using at least **three interesting nouns, three interesting adjectives and one simile** to set up the scene, mood and interest in the story. Make sure that you use complex sentences in your orientation.



**Extension:** You may like to finish your narrative.

## Example - Orientation

Noun Adjective Simile

The protective crows woke at dusk and guarded the dilapidated country house. Their shrieking caws sounded like an alarm clock awakening the dead. No one had seen Old Mrs Smith since her nasty husband disappeared mysteriously, 5 years ago. When Emmanuel and Amber were asked to check on their neighbour they came across a terrifying scene.....





## Fast Finisher

Click here to hear instructions

Complete a Reading Eggspress Task.

[Reading Eggspress](#) - Click here



# Break 1

## Blinky Thinky

1. Stand up.
2. Blink your left eye while simultaneously snapping your fingers with your right hand.
3. Now blink your right eye while snapping with your left hand.
4. Try to blink one eye while snapping your fingers on the opposite side's hands 15 times in a row, alternating eyes. In other words, blink your left eye while simultaneously snapping with your right hand and then blinking your right eye while snapping with your left hand.



# Mathematics

Student resources

# Warm Up

## Division

Click here to hear instructions

Set a timer for 10 minutes and play [Cave Run Division](#) to warm up.



[Click here to hear instructions](#)

## Mental division strategies – use multiplication facts

Knowing our multiplication facts helps us with division as they do the reverse of each other. They are inverse operations.

$$3 \times 5 = 15$$

$$15 \div 5 = 3$$

5 x 4 = 20

□ ÷ □ = □















Can you work out the division question that is the reverse of this equation? Complete this in your exercise book.

# Task 1

[Click here to hear instructions](#)

Division - Complete in your exercise book. You can use a calculator to check if your answer is correct. Use a red pen to mark your work.

Use your knowledge of multiplication facts to help answer these division questions:

- a  $56 \div 7$    $\underline{8} \times 7 = 56$    $56 \div 7 =$
- b  $121 \div 11$    $\underline{\quad} \times 11 = 121$    $121 \div 11 =$
- c  $72 \div 8$    $\underline{\quad} \times 8 = 72$    $72 \div 8 =$
- d  $49 \div 7$    $\underline{\quad} \times 7 = 49$    $49 \div 7 =$
- e  $36 \div 9$    $\underline{\quad} \times 9 = 36$    $36 \div 9 =$
- f  $64 \div 8$    $\underline{\quad} \times 8 = 64$    $64 \div 8 =$
- g  $108 \div 12$    $\underline{\quad} \times 12 = 108$    $108 \div 12 =$



## Task 2 - Use the Google Doc on Google Classroom called "Monday W5 Mathematics Activity" to upload an image of your maths work Task 2 from your exercise book.

[Click here to hear instructions](#)

Division - Complete in your exercise book. You can use a calculator to check if your answer is correct. Use a red pen to mark your work.

Now try these:

a  $81 \div 9 =$

c  $21 \div 3 =$

e  $42 \div 7 =$

g  $36 \div 4 =$

i  $39 \div 3 =$

b  $40 \div 5 =$

d  $54 \div 6 =$

f  $63 \div 9 =$

h  $45 \div 9 =$

j  $24 \div 6 =$



Doing maths without knowing your multiplication facts is hard. Learning them makes your life much easier. It's worth persevering to conquer them!

# Task 3

[Click here to hear instructions](#)

Division - Complete in your exercise book. You can use a calculator to check if your answer is correct. Use a red pen to mark your work.

Fill in the division wheels. Use multiplication facts to help you.

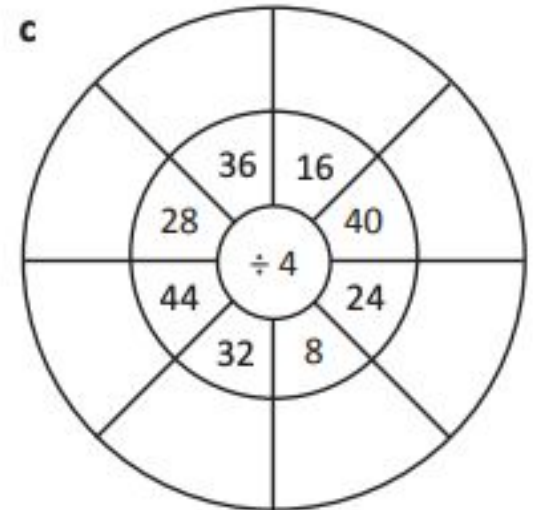
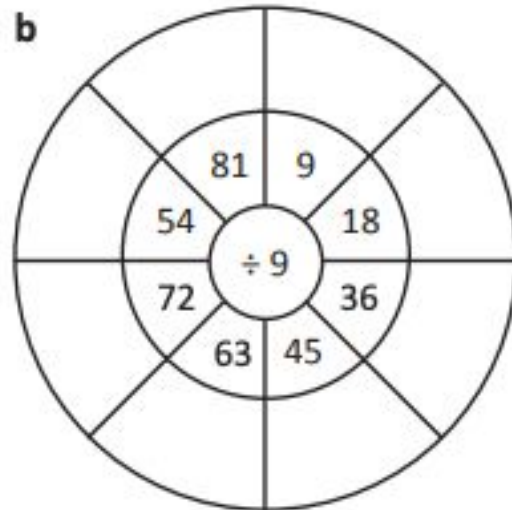
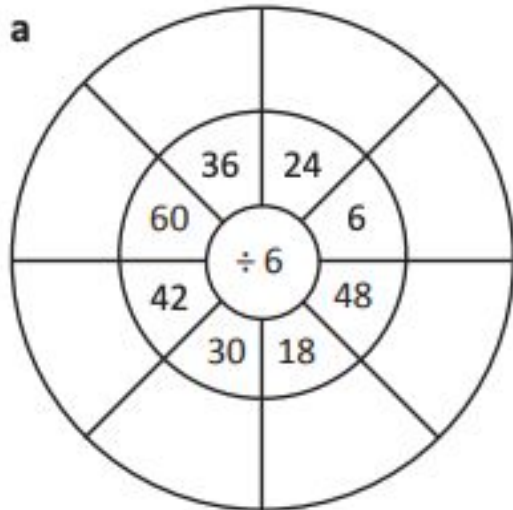



Click here to hear instructions

## Extension

Complete an activity on Mathletics.





# PDHPE

## Student resources

# Monday

## Hand and racquet control

Follow the link below to watch the episode and join in the striking fun with Adam and Elissa.

[GetActive@Home – Episode](#)

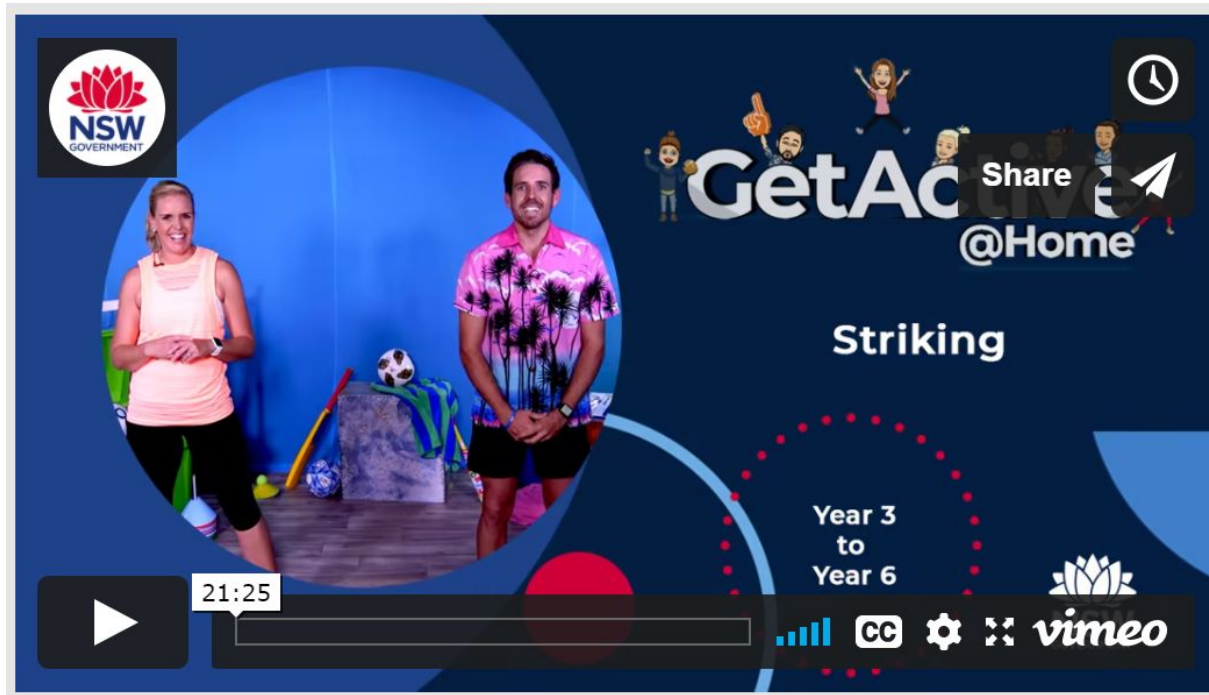



## Break 2

Eat outside on a picnic rug with whoever else is home in your family and chat to one another.



# Science

With Mr T

# Forces- Gravity

**How does a rocket overcome the force of gravity to blast off into space?** Recommend a big screen, volume up and popcorn for this video

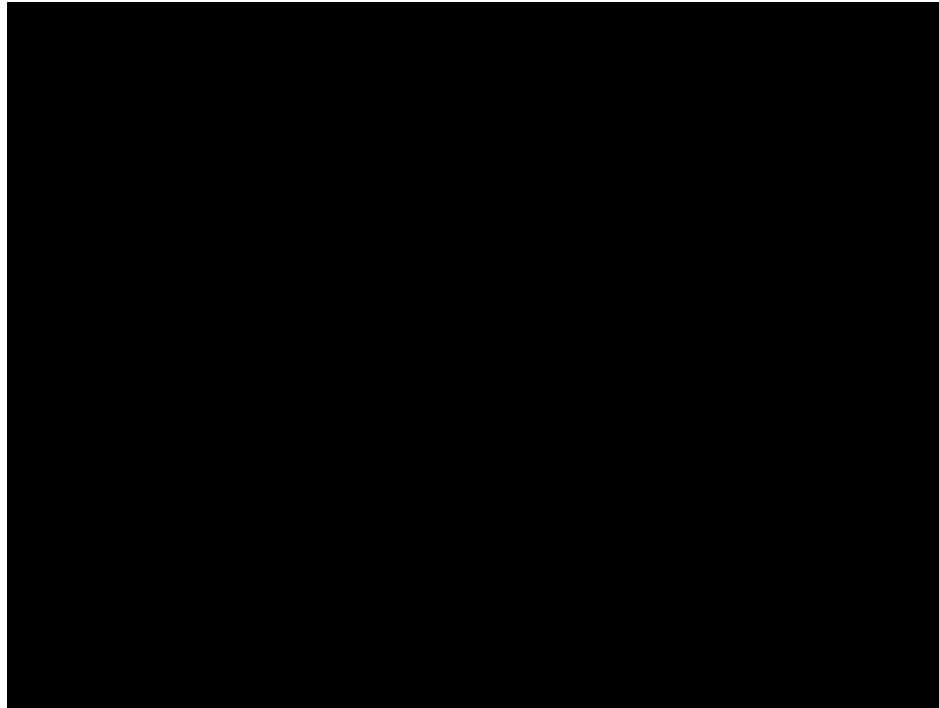

<https://safeshare.tv/x/AYzILhinEeQ#> if the video doesn't work

# Forces- Gravity

## Saturn V Rocket: Getting Man to the Moon

The video you just watched was from the First Moon Mission 52 years ago back in 1969. Years of study, scientific research and breakthroughs, training and mathematics (SO MUCH MATHS) led to humans stepping on the Moon.

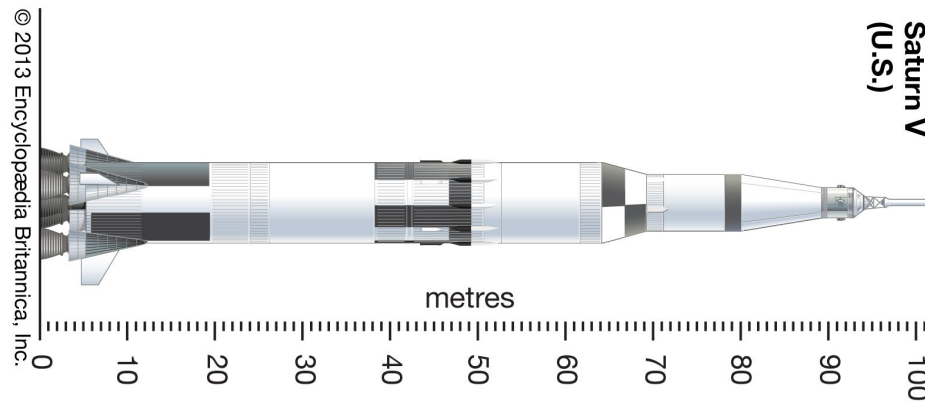



**From launching the rocket to landing on the Moon, what forces do you think the astronauts, the spacecraft and scientists would have encountered? What was causing these forces? Write these in your workbook**

# Forces- Gravity

## Saturn V Rocket: Getting Man to the Moon

Sir Isaac Newton, discoverer of gravity, created something called the Laws of Motion. This was what he learned about how objects move, and how to make them move.

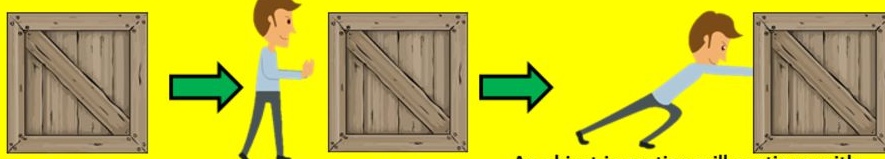
To lift a **very** heavy rocket ship off the ground, you will need a **lot** of power. Scientist had to use all three of his laws to figure out how to get the rocket off the ground.

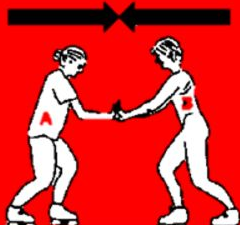
<b>NEWTON'S FIRST LAW OF MOTION</b>	 <p>The diagram illustrates Newton's First Law of Motion in three stages. On the left, a wooden crate sits at rest. A green arrow points to the middle stage where a person stands next to the crate. Below this is the text: "Unless acted on by an unbalanced force". A second green arrow points to the right stage where the person is pushing the crate, and it is moving to the right. Below this is the text: "An object in motion will continue with constant speed and direction unless acted on by unbalance force".</p> <p>An object at rest will remain at rest</p> <p>Unless acted on by an unbalanced force</p> <p>An object in motion will continue with constant speed and direction unless acted on by unbalance force</p>
<b>NEWTON'S SECOND LAW OF MOTION</b>	<p>The acceleration of an object depends on the mass of the object and the amount of force applied</p>  <p>The diagram shows a blue car on a green surface. A large yellow arrow labeled "FORCE" points to the left side of the car. A second large yellow arrow labeled "ACCELERATION" points to the right side of the car.</p> <p>FORCE</p> <p>ACCELERATION</p>
<b>NEWTON'S THIRD LAW OF MOTION</b>	<p>For every action force, there is a reaction force equal in strength and opposite in direction</p>  <p>The diagram shows two people on roller skates facing each other. They are pushing their hands against each other. Above them are two black arrows pointing in opposite directions, one to the left and one to the right, representing the action and reaction forces.</p>



## NEWTON'S FIRST LAW OF MOTION



An object at rest  
will remain at rest



Unless acted on by an  
unbalanced force



An object in motion will continue with  
constant speed and direction unless acted on  
by unbalance force

If the Saturn V just sat there, with no fuel, would it fly into space? Nope. It is “at rest” or balanced. The only way to make it move is for a force (like rockets firing) to act upon it.

The Saturn V weighed 2.8 **million** kilograms (2,800,000kg). In space, it would weigh **zero** kilograms (0kg). There is no gravity in space. Because of this, if something is moving in space, it will **not** stop until something else (an external force) stops it, like gravity or hitting another object/planet.

Scientists had to think about this for when the rocket was on Earth, in space AND on the moon.

## NEWTON'S SECOND LAW OF MOTION

The acceleration of an object depends on the mass of the object and the amount of force applied



At the beginning of the launch in the video, it didn't really look like the Saturn V was moving that fast, did it? That's because it is **really** heavy (don't forget, 2.8 **MILLION** kilograms!). It is **massive**. The mass of the object is huge. So to lift it, you need to apply an **even larger** amount of force to lift off the ground. The Saturn V rocket was so powerful that it had 3.4 **million** kilograms of thrust. That is more than the mass of the rocket, so that it can lift off the ground. After lifting off, the rocket starts to move faster, or accelerate, to space!

Fun fact, 3.4 million kilograms of thrust is 160 million (160,000,000) horsepower. Currently, the fastest car in the world (the SSC Tuatara) has 1,750 horsepower. That means the Saturn V had the power of 91,428 SSC Tuataras.

## NEWTON'S THIRD LAW OF MOTION

For every action force, there is a reaction force equal in strength and opposite in direction



If you push against a wall, does the wall fall down? Unless you are the Hulk or Mr T, the answer is probably no.

What if you throw a ball against the wall? If you throw it softly, it does not rebound very far. If you throw it really hard, it will rebound a lot further. That's because whatever power or force you put into something, you will get the same force back. Ever wondered why people can run faster than you? Or jump higher than you? That's because they can push harder against the ground than you, and when they push down, all that power and force hits the ground and then pushes **back** with the same power or force.

For the Saturn V rocket to take off from the ground, it had to hit the ground with so much force that it would "push" the rocket back and lift it off the ground.

**After Mr T's explanation, watch the launch video again and see if you can make connections with the Laws of Motion and the launch.**

# Forces- Gravity

## Saturn V Rocket: How did it work?

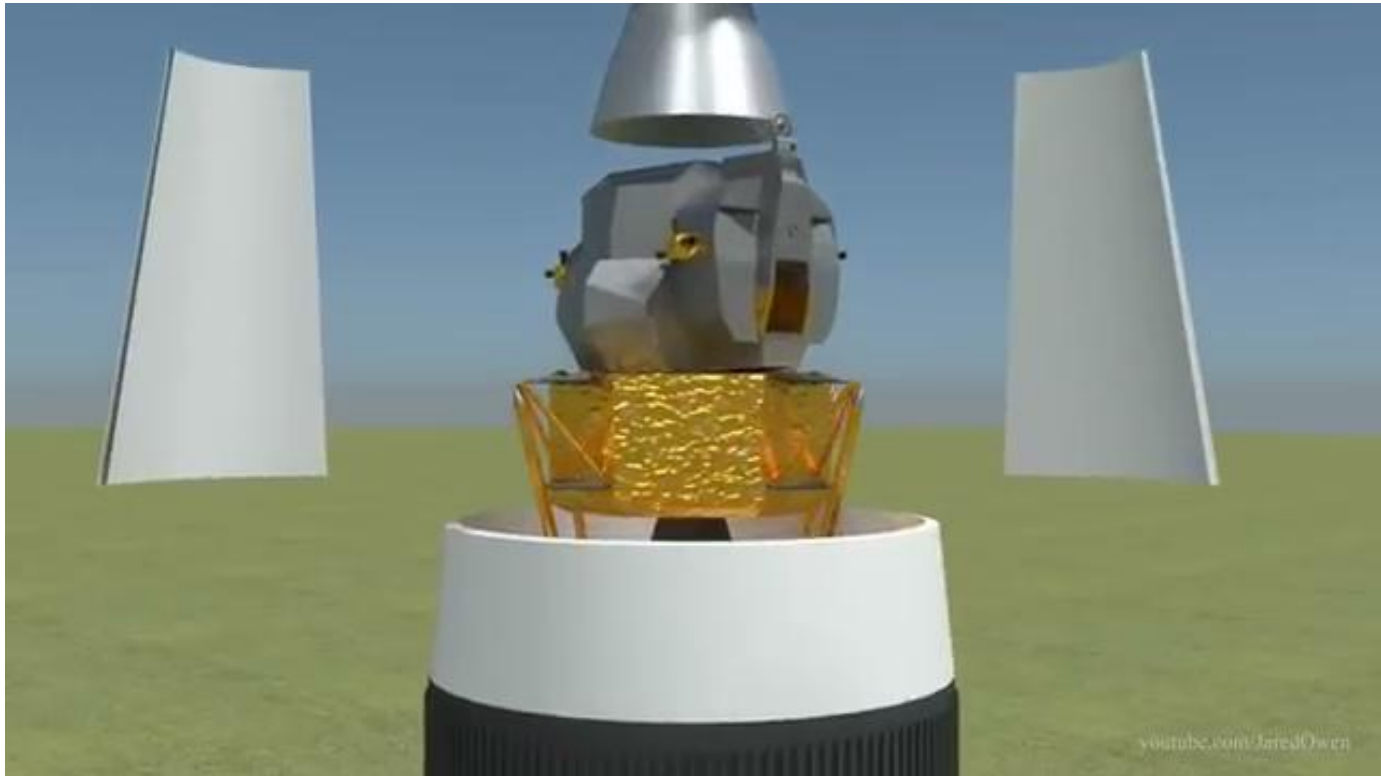

<https://safeshare.tv/x/ss610a847ad3f70#> if video does not work

# Forces- Gravity

## Forces that are going to try to ruin your spaceship



After watching the “how did it work” video, think about the following questions and answer them in your workbook:

Why do you think the Saturn V had to use “stages” in its flight?

Why couldn't they just keep the whole rocket together to get to the moon?

Why didn't the smaller stages need more boosters?



# Forces- Gravity

## You are now a Rocket Scientist. Build a spaceship to get to Mars

Can you design a spaceship that could travel to Mars? What would it look like? What would be different to the Saturn V?

Draw and label your design in your workbook. Research to see how long it would take to travel to Mars, and think about what supplies you would need

Use the Space X website to give you ideas for your designs

<https://www.spacex.com/human-spaceflight/>



# Reflection for Monday's lessons

[Click here to hear instructions](#)

Complete this in your exercise book. You can take a photo and upload to Google Classroom. We love reading your reflections.

Mrs Freney and Mrs Roda.

## Reflection Points:

- 1 thing you liked and why
- 1 thing you found hard
- 1 thing you'd like more of

good morning



# Kearns PS Online Learning – Stage

Daily Lessons

good morning





# Tuesday

## Tuesday



# English

Student resources



# Listen

Click here to  
hear  
instructions

[Listen to the Squiz Kids Podcast](#) - Click here

**Write a 3-2-1 response in the Google Classroom thread.**

**Write 3 things you learnt, 2 questions you have and one opinion that you have. You can respond to your classmates as well.**

**This is a compulsory task meaning that we expect a 3-2-1 response from everyone today.**

**SQUIZ  
KIDS**





# Word Work

## Literacy

### Suffixes – ‘able/ible’

1. A suffix is a few letters put at the end of a word to change its meaning.
2. Adding ‘**able**’ or ‘**ible**’ to the end of a word means that the subject is capable of or suitable for something. (Sometimes the ending of the base word is changed slightly before ‘**able/ible**’ is added.)
3. Take this sentence for eg.

Holly’s new raincoat was reversible. It means the raincoat was capable of being reversed.

**Word Work**- Use Google doc on Google Classroom called “Tuesday W5 English Activity” to complete this task

## Literacy

# Suffixes – ‘able/ible’

## Task

1. For each of these words, determine what the subject is capable of or suitable for and then use the word in a sentence.
2. For eg: **Edible means suitable for eating.** The decorations on the cake were made of icing and therefore were edible.

**Word Work** - Use Google doc on Google Classroom called "Tuesday W5 English Activity" to complete this task

Here is another example: **Breakable** means something can break. **Be careful when holding the vase because it is breakable if you drop it.**

Complete the same for the following words:

**breakable**

**disposable**

**believable**

**accessible**

**extendible**

**flexible**

**Extension:** Make a list of at least 10 more words you can think of or find that end with the suffix 'able/ible'.

# Reading Response

Find a comfortable spot without distractions and spend 20-30 minutes reading a novel of your choice. You can choose your own novel or a novel from Epic Books. Set a timer for 20-30 minutes.

[Click here for access to EPIC](#)



## Activity: In your exercise book

- Choose a character from your novel. Think about the things that have happened to them and the choices they have made in the story.
- Write the **Title and Author of Your Book/Character Questions** in your exercise book.
- Write the name of the character.
- Write a list of 5 open-ended questions that you would like to ask that character that would help you to understand their personality, choices and the events better.
- Highlight your three best questions. (Open-ended questions are questions that cannot be answered with yes or no.)



## Fast Finisher

Click here to  
hear  
instructions

Complete a Reading Eggspress Task.

[Reading Eggspress](#) - Click here

# Break 1

## Tai Chi Relaxation

You will need a calm and peaceful space for this activity in order to enjoy the benefits of Tai Chi.

**Activity:** Tai chi is a Chinese martial art practiced for its defence training, its health benefits and meditation. Try some Tai Chi movements by joining in with the following tutorial:

[Click here for the Tai Chi Video](#)





# Mathematics

Student resources

# Warm Up

## Division

Click here to  
hear  
instructions

Set a timer for 10 minutes and play [Penalty Kicks - Free Division Facts Practice](#) to warm up.



# Division

## Mental division strategies – use multiplication facts

Knowing our families of facts is also helpful.

$$3 \times 5 = 15$$

$$5 \times 3 = 15$$

$$15 \div 5 = 3$$

$$15 \div 3 = 5$$

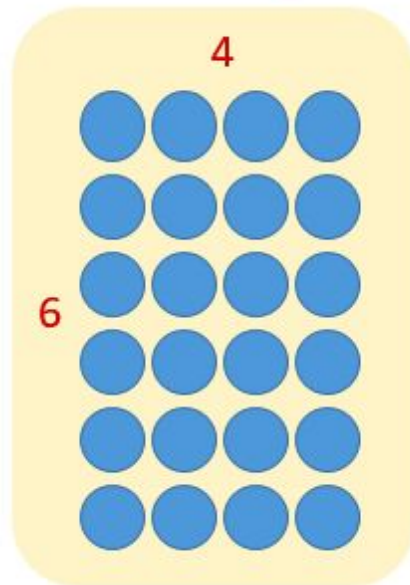

### Fact Family

$$6 \times 4 = 24 \quad 24 \div 4 = 6$$

$$4 \times 6 = 24 \quad 24 \div 6 = 4$$

# Task 1

Division - Complete in your exercise book.

Complete the following patterns. How many more multiplication and division facts can you find, given the first fact?

**a**       $7 \times 8 = 56$

$$8 \times 7 = \square$$

$$56 \div \square = 8$$

$$\square \div 8 = 7$$

**b**       $8 \times 9 = 72$

$$9 \times 8 = \square$$

$$72 \div \square = 9$$

$$\square \div 9 = 8$$

**c**       $7 \times 9 = 63$

$$9 \times 7 = \square$$

$$63 \div \square = 9$$

$$\square \div 9 = 7$$

## Task 2 - Use the Google Doc on Google Classroom called "Tuesay W5 Mathematics Activity" to upload an image of your maths work Task 2 from your exercise book.

Write down another multiplication fact and two division facts for each question.

a  $6 \times 7 = 42$

E.G  $7 \times 6 = 42$   
 $42 \div 7 = 6$   
 $42 \div 6 = 7$

b  $5 \times 9 = 45$

c  $9 \times 6 = 54$

d  $17 \times 8 = 136$

e  $12 \times 8 = 96$

f  $11 \times 21 = 231$



## Task 3

**Division - Complete in your exercise books.**

Look at these two division facts:       $20 \div 5 = 4$       and       $20 \div 4 = 5$

Imagine you're explaining to a younger child how they're related yet different. How would you do it?  
What would you say/write/draw?





Click here to  
hear  
instructions

## Extension

Complete an activity on Mathletics.



## Break 2

5,4,3,2,1

1. Stand up.
2. Choose 5 different movements to complete in descending order e.g. do 5 star jumps, spin around 4 times, hop on one foot 3 times, do 2 push ups, walk around the desk once.



# Geography of Asia

With Mrs Gveric



# Asia

This week you are going to look at some of the different geographical features of Asia.

Features are what makes a place different, and it could be because of where it is located, temperature, natural landmarks, man made landmarks – all the things that make a place unique.

As you have a look, think about how this is different from Australia and why you think it is different.

## Where is Asia?

Asia is the largest of the world's continents, covering about 30% of the Earth's land area. It is also Australia's closest neighbour.





Asia, being such a large continent, has a diverse range of geographical features.

Some of the countries of Asia are stand-alone islands or made up of a group of islands, known as archipelagos.

Three of the world's oceans flow in and around the region. Other bodies of water include seas, lakes and rivers, some of which flow from melted glaciers in the highlands.

Large mountain ranges, low lying plateaus and expansive deserts are characteristic of many Asian countries.





## Asia's Biomes

The world can be divided into biomes. Several different biomes can be found in Asia.



### Key Terms

A biome is an area with a distinctive climate and vegetation.

# Biomes Map of the World

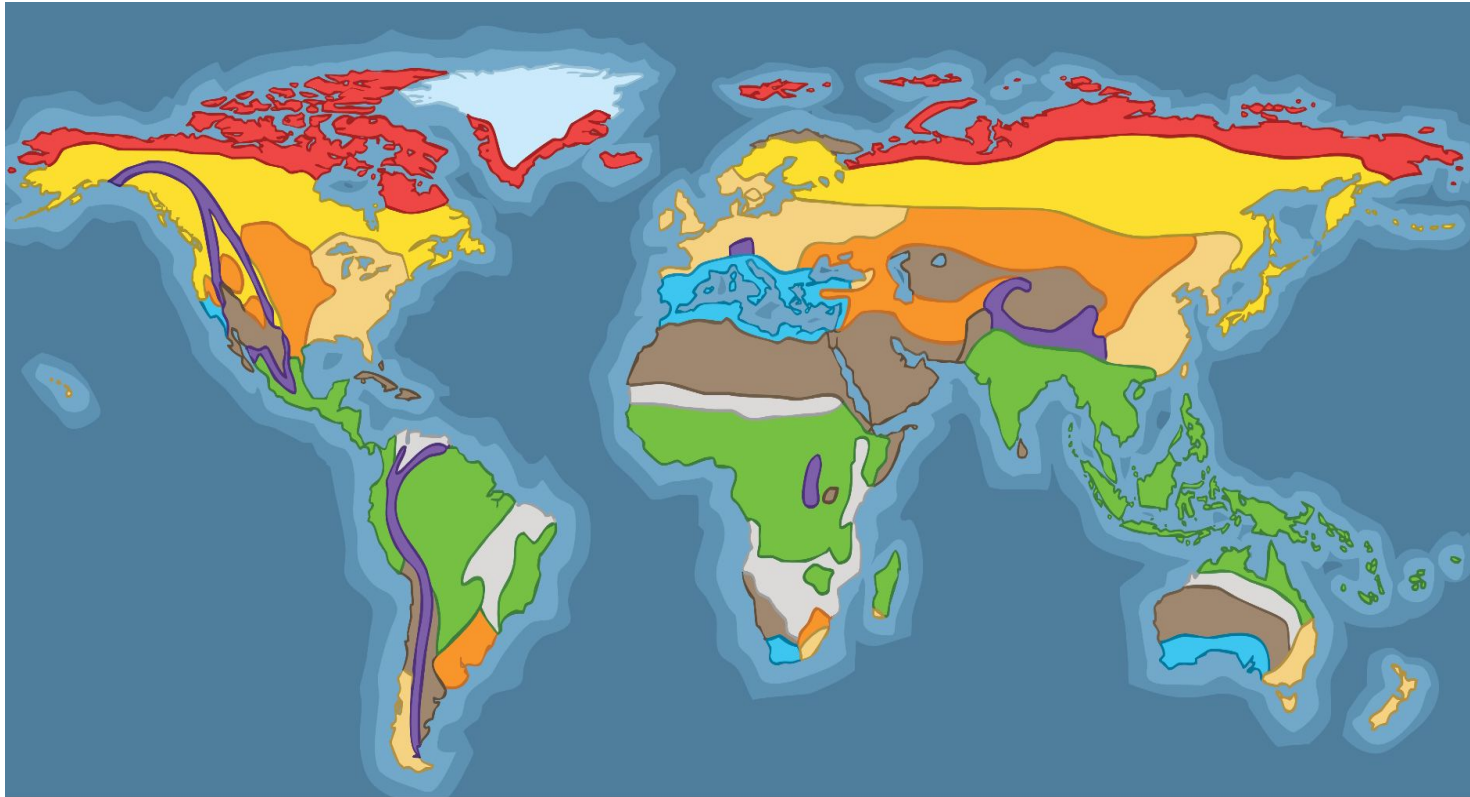

- |                   |         |           |           |                     |
|-------------------|---------|-----------|-----------|---------------------|
| Tropical Forest   | Savanna | Desert    | Chaparral | Temperate Forest    |
| Coniferous Forest | Tundra  | Mountains | Polar Ice | Temperate Grassland |

Which biomes are found in Asia?

# 1. Deserts



Asia contains several deserts. The largest is the Gobi Desert found between China and Mongolia. It is mainly made of rock, rather than sand, and parts of the Gobi Desert receive less than 100mm annual rainfall. Saudi Arabia, Yemen and Oman also have hot desert.



## 2. Temperate Grasslands

Large areas of flat grassland and shrublands are known as plains or steppes. They have very few trees. The West Siberian Plain is in central Russia. It is one of the world's largest areas of continuous flatland. It contains some of the world's largest swamps and flood plains.

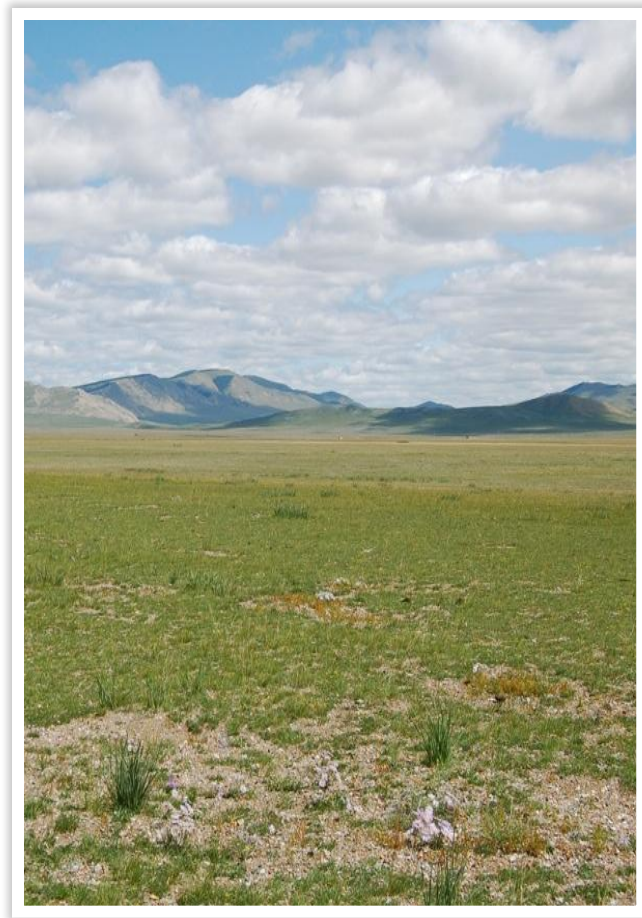



### 3. Coniferous Forests

Also known as Taiga or Boreal.  
This forms a belt across the middle of Russia.

Why do trees have:

A tall and conical-shape?

To let snow slide off.

Short branches and wax-covered  
needle-shaped leaves?

To reduce water-loss.

Shallow roots to survive long cold  
winters?

The ground will be frozen for more than six months of  
the year.

Tree species include fir, spruce and pine.

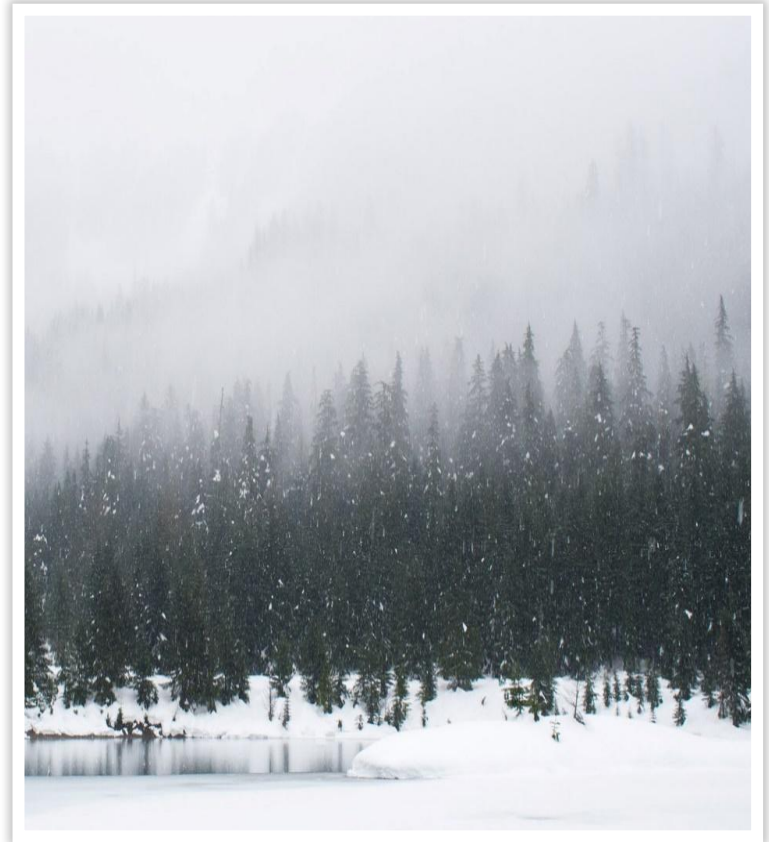

## 4. Tropical Forests

Tropical rainforests are found in south-east Asia. They are warm and wet. Tropical rainforests contain thousands of species of plants, animals, insects and birds. They have five distinct layers of vegetation.

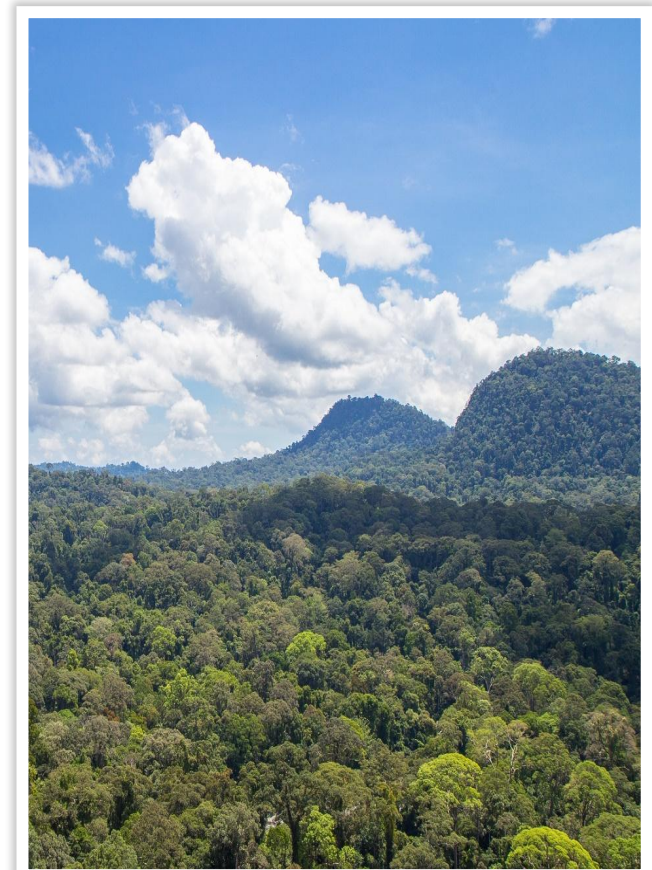
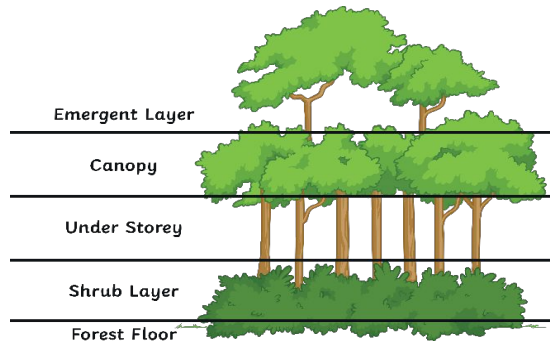



## 5. Tundra

Tundra is found in northern Russia. Temperatures are very low and most of the ground is permanently frozen (permafrost). Surface water cannot drain away so land can be marshy. Precipitation is low and normally falls as snow. Plants are rarely taller than 30 centimetres and consist of moss, lichen and grasses.



## 6. Mountains

The largest mountain range in Asia is the Himalayas. They began forming when the Indian subcontinent collided with the Eurasian continent about 50 million to 55 million years ago. The Himalayas are still growing about 5 centimetres every year. Asia is home to many plateaus. The Tibetan Plateau is the largest highest area and is often called the “Rooftop of the World”. It has many important glaciers and about 2 billion people depend on the rivers fed by the plateau glaciers.



### Dictionary Meaning of Plateau

A plateau is an area of relatively high land. However, the land at the top of a plateau is flatter, not mountainous.

## Task: Biomes Found in Asia

Find the information in the slides to answer these questions about Biomes in a google doc. Share this doc with me on [rebecca.taylor6@education.nsw.gov.au](mailto:rebecca.taylor6@education.nsw.gov.au).

Write the answers in full sentences.

Q1. Where would you find the Gobi desert?

Q2. What are the 5 distinct layers of vegetation in a tropical forest?

Q3 By how much is the himalayas growing every year?

Q4 Where would you locate Tundra?

# Trivia Time

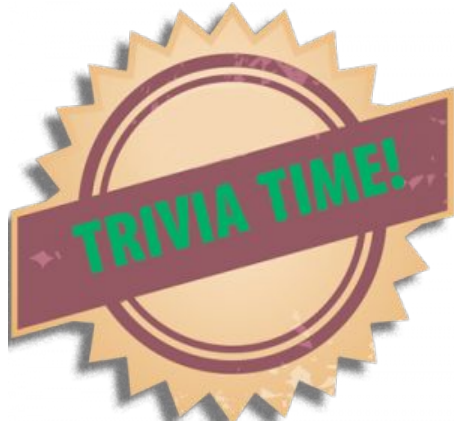

Using Google, search to see if you can find the answers to these questions. When you find your answers create a Google Slide with your answers. You might want to include some pictures of the places.

Name these geographical features of Asia and their country.

**(What is it called and where is it?)**

a The highest mountain in the world

\_\_\_\_\_

b The third longest river in the world

\_\_\_\_\_

c The world's deepest freshwater lake

\_\_\_\_\_

d The lowest point in the world

\_\_\_\_\_

e The tallest volcano in Asia

\_\_\_\_\_

f The largest bay in the world (by area)

\_\_\_\_\_



Asia has such a diverse range of geographical features.

We will explore these more over the next few weeks.

A great way to have a look at some of these places and what they look like is through Google Earth.

So, when you are done go and have a look and have a think about the different features you can see.

<https://www.google.com.au/earth/>

# Reflection for Tuesday's Lessons

Complete this in your exercise book. You can take a photo and upload to Google Classroom. We love reading your reflections.

Mrs Freney and Mrs Roda.

## Reflection Points:

- 1 thing you liked and why
- 1 thing you found hard
- 1 thing you'd like more of

Click here to  
hear  
instructions





# Kearns PS Online Learning – Stage

Daily Lessons





# Wednesday

Student resources



# English

Student resources



Click here to  
hear  
instructions

## Listen

[Listen to the Squiz Kids Podcast](#) - Click here

**Write a 3-2-1 response in the Google Classroom thread.**

**Write 3 things you learnt, 2 questions you have and one opinion that you have. You can respond to your classmates as well.**

**This is a compulsory task meaning that we expect a 3-2-1 response from everyone today.**

**SQUIZ  
KIDS**



# Reading Response

Click here to  
hear  
instructions

Continue reading your **fiction novel** from yesterday. It can be your own novel or a novel from your EPIC account. Set a timer and read for **20-30 minutes**.

[Click here for access to EPIC](#)

## Activity:

Find a comfortable spot without distractions and spend **20-30 minutes** reading your novel.

Longer fiction texts generally have a major complication that runs throughout the story and is resolved at the end, with a series of smaller complications and resolutions that present themselves along the way.



# Reading Response - Use Google doc on Google Classroom called "Wednesday W5 English Activity" to complete this task

## Task

Write the Title/ Author as your heading:

Example: Dancing Horses by Hannah Horseyhoof



**Answer or respond to the following instructions and questions**

1. Write a short (one paragraph) summary of the most recent complication and resolution from your novel. What was the problem and how was it solved?
2. Was it the resolution you expected? Why or why not?
3. How else might this complication have been resolved?
4. Can you think of a new complication these events might cause?



## Vocabulary Editing Skills

**Finish the Story: Boat Disaster** and make the story more interesting.

**Task:** Practise editing skills including improving vocabulary choices by completing this writing game titled “Finish the story: Boat Disaster”

[Click here for the Writing Game](#)

**Reflection:** In your exercise book write about how you made the story more interesting.



## Fast Finisher

Click here to  
hear  
instructions

Complete a Reading Eggspress Task.

[Reading Eggspress](#) - Click here

[Click here to hear instructions](#)

# Break 1

## Wave Breathing

1. Covering your ears with your hands, take long and slow breaths in and out as you imagine waves rolling back and forth.
2. Listen to the sound of your slow breathing for 2 minutes.



# Mathematics

Student resources



# Warm Up

## Division

Click here to  
hear  
instructions

Set a timer for 10 minutes and play [Rooftop Ride - Free Division Math Game](#) to warm up.



## Mental division strategies – inverse operations

As we know, multiplication and division are inverse operations.

$$8 \times 9 = 72$$

This means they do the reverse of each other:

$$72 \div 9 = 8$$

We can use our knowledge of the times tables to help us answer division questions.

$$56 \div 7 = 8$$

$$56 \div 8 = 7$$

Can you work out the multiplication equations that are the reverse of these division questions?



# Task 1

Complete in your exercise book. You can use a calculator to check if your answer is correct. Use a red pen to mark your work.

Complete these fact families:

**a**  $8 \times \square = 24$

$24 \div 8 = \square$

**b**  $8 \times \square = 32$

$32 \div 8 = \square$

**c**  $7 \times \square = 42$

$42 \div 7 = \square$

**d**  $9 \times \square = 27$

$27 \div 9 = \square$

**e**  $5 \times \square = 25$

$25 \div 5 = \square$

**f**  $8 \times \square = 96$

$96 \div 8 = \square$

## Task 2

Complete in your exercise book. You can use a calculator to check if your answer is correct. Use a red pen to mark your work.

What do we do when there are remainders? We have to guess, check and improve.  
 $27 \div 5 = ?$   
 $5 \times 6 = 30$  Too high  
 $4 \times 5 = 20$  Too low, there are 7 left over  
 $5 \times 5 = 25$  There are 2 left over so  $27 \div 5 = 5 \text{ r } 2$

Use your knowledge of multiplication to help you mentally solve these problems. Some will have remainders.

a  $36 \div 3 =$

b  $63 \div 7 =$

c  $121 \div 11 =$

d  $120 \div 10 =$

e  $25 \div 6 =$

f  $37 \div 8 =$

g  $68 \div 11 =$

h  $113 \div 12 =$



THINK

**Task 3** - Complete in your exercise book. Once you have completed, take a picture of your work and upload it to “Wednesday W5 Mathematics Activity” doc on Google Doc.

Try these:

- a 42 cupcakes are shared evenly amongst you and 7 friends. How many whole cakes does each person receive?
  
  
  
  
  
  
  
  
  
  
- b How do you recommend sharing the remainder?
  
  
  
  
  
  
  
  
  
  
- c 102 pencils need to be put into packets of 12. How many full packs can be made? How many pencils are left over?



Click here to  
hear  
instructions

## Extension

Complete an activity on Mathletics.





# PDHPE

## Student resources

# Wednesday

## Forehand and backhand strike

Follow the link below to watch the episode and join in the striking fun with Adam and Elissa.

[GetActive@Home – Episode](#)

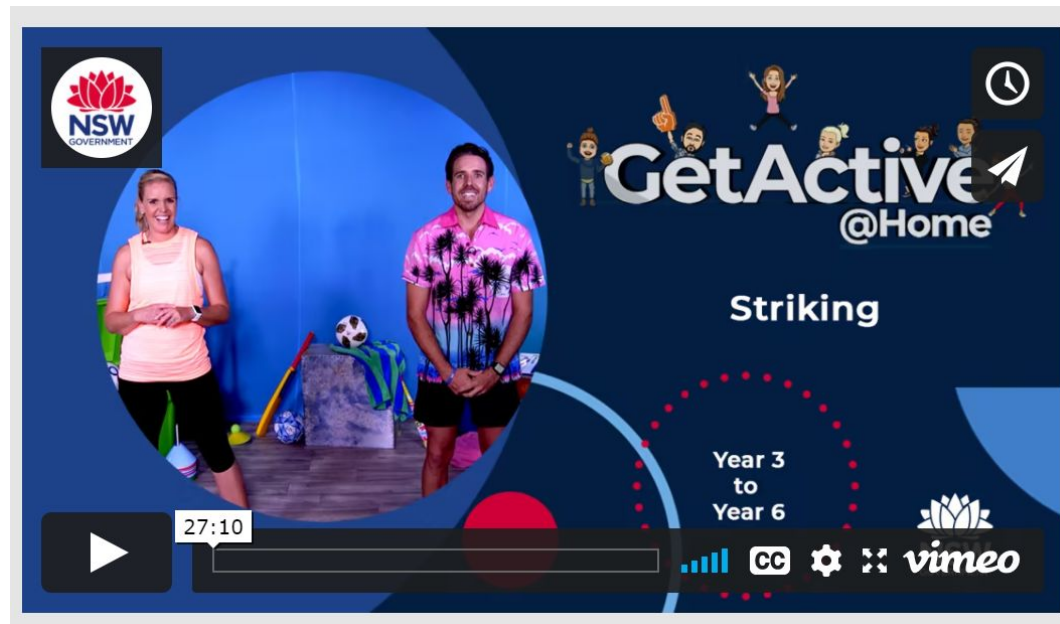



## Break 2

Have a “best joke” competition with your siblings.

Share your joke on the best joke thread on our Google Classroom Stream.



# CAPA

With Mrs Nott



# Shovels, Picks and Pans

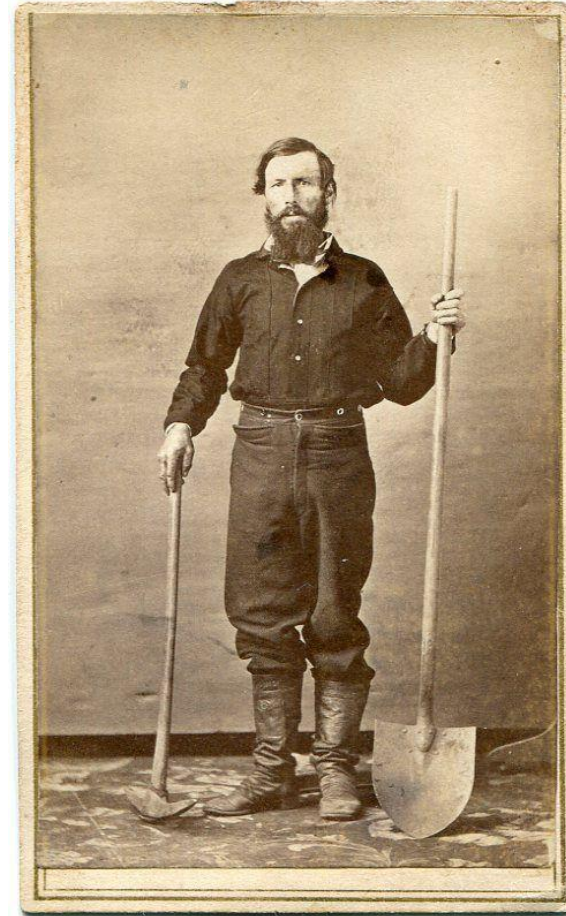
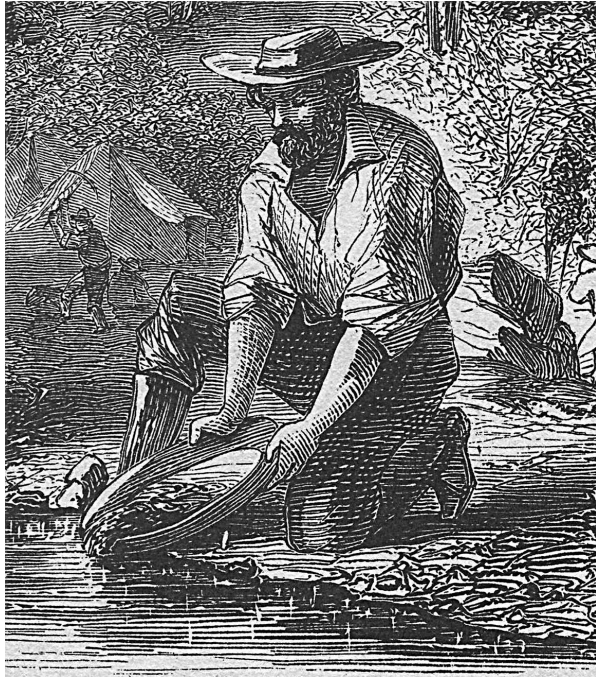

**Learning Intention: We are learning to acknowledge how history can be revealed through art.**



**Julian Ashton is an English born artist who migrated to Australia in 1878.**

**Much of his artistic experience came from his employment as an artist depicting the history of life in Australia in the 1880s and 1890s.**

**There is an art school named after him.**

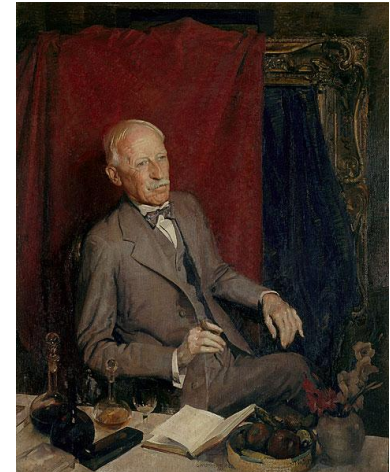



# Some of Julian Ashton's Art

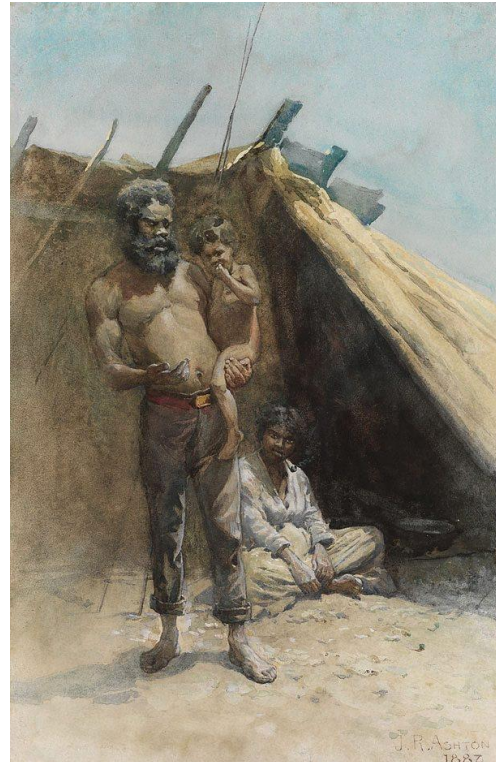
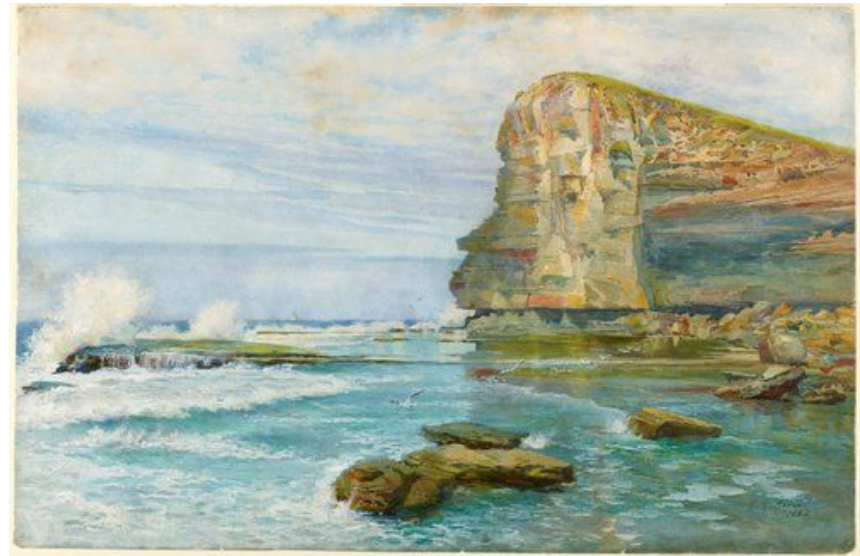

Let's take a close look  
at the artwork called  
*The Prospector.*





## Task: Julian Ashton Art

Answer the following questions in your exercise book.

- What does the physical stance of the man suggest?
- What do you notice about his clothes?
- What has he been doing?
- Where do you think he is?



# Reflection

Complete this in your exercise book. You can take a photo and upload to Google Classroom. We love reading your reflections.

Mrs Freney and Mrs Roda.

## Reflection Points:

- 1 thing you liked and why
- 1 thing you found hard
- 1 thing you'd like more of

Click here to  
hear  
instructions



# Kearns PS Online Learning – Stage

Daily Lessons





# Thursday

Student resources





# English

Student resources



Click here to  
hear  
instructions

## Listen

[Listen to the Squiz Kids Podcast](#) - Click here

**Write a 3-2-1 response in the Google Classroom thread.**

**Write 3 things you learnt, 2 questions you have and one opinion that you have. You can respond to your classmates as well.**

**This is a compulsory task meaning that we expect a 3-2-1 response from everyone today.**

**SQUIZ  
KIDS**



# Reading Response - Genre

[Click here to hear instructions](#)

## Activity:

Find a comfortable spot without distractions and spend 20-30 minutes (set a timer) reading your novel. [Click here for access to](#)

[EPIC](#)

Fictional texts can take the form of a variety of genres. Remember when we learnt about genres in class last term. For example historical fiction, science fiction, fantasy, realistic fiction, horror etc.

**Task:** In your exercise book write the title of your fictional text. Answer the following questions using full sentences.

1. **What is the genre of your fictional text?**
2. **Give 3 examples to explain why your novel is that genre.**
3. **What genre do you enjoy reading the most and why?**
4. **What genre do you like reading the least and why?**

# Writing For Enjoyment

[Click here to hear instructions](#)

## Task:

1. Find a comfortable spot without distractions and spend 30 minutes writing something of your own choosing.
2. You may wish to write a story, a poem, a letter, a journal entry, instructions for a favourite recipe or hobby, etc.
3. It doesn't matter what you write, just that you remain on task so that your words and ideas have a chance to 'flow' and that you enjoy the writing experience.
4. During this draft stage, don't worry about making your writing perfect, just get the words onto the page.

# Writing For Enjoyment

When you are finished, you must edit your writing. Below is a list of things that must be completed when editing, just like a checklist.

## Things to do:

- Correct spelling
- Grammar and punctuation
- Improve vocabulary choices
- Add, remove or rearrange text to improve flow, clarity or detail

# Break 1

## Rub-a-Dub

1. Stand up.
2. Pat your head with your right hand.
3. Rub your stomach with your left hand.
4. Switch hands.

**Extra challenge:** Sing your favourite song at the same time as you are doing this.





# Mathematics

Student resources

# Warm Up

## Division

Click here to  
hear  
instructions

Set a timer for 10 minutes and play [Driver Highway Division](#) to warm up.



[Click here to hear instructions](#)

## Written methods – short division

In short division, we use our knowledge of multiplication to help us. We can split 936 into  $900 + 30 + 6$ .

$$\begin{array}{r} 3 \quad 1 \quad 2 \\ 3 \overline{) 9 \quad 3 \quad 6} \end{array}$$

900 divided by 3 is 300, so we put a 3 in the hundreds place.

30 divided by 3 is 10, so we put a 1 in the tens place.

6 divided by 3 is 2, so we put a 2 in the units place.

$$936 \div 3 = 312$$

# Task 1

Click here to hear instructions

Complete in your exercise book. You can use a calculator to check if your answer is correct. Use a red pen to mark your work.

Divide these numbers:

a

$$4 \overline{) 84}$$

b

$$5 \overline{) 55}$$

c

$$3 \overline{) 93}$$

d

$$9 \overline{) 990}$$

e

$$4 \overline{) 484}$$

f

$$6 \overline{) 666}$$

g

$$3 \overline{) 999}$$

h

$$2 \overline{) 462}$$

i

$$3 \overline{) 693}$$

[Click here to hear instructions](#)

Sometimes it's easier to split the numbers differently. We can also split 936 into  $900 + 36$ .

$$\begin{array}{r} 3 \quad | \quad 1 \quad | \quad 2 \\ 3 \overline{) 9 \quad | \quad 3 \quad | \quad 6} \end{array}$$

900 divided by 3 is 300 so we put a 3 in the hundreds place

36 divided by 3 is 12. We put the 1 in the tens place and the 2 in the units place.

$$\mathbf{936 \div 3 = 312}$$



## Task 2

Complete in your exercise book. You can use a calculator to check if your answer is correct. Use a red pen to mark your work. When you are completed, upload a picture of your work into the “Thursday W5 Mathematics Activity” doc on Google Classroom.

[Click here to hear instructions](#)

In these problems, if there are no tens in a number we put a 0 in to show this and also to hold the place of the other numbers!



Decide how you'll split these numbers and then divide. Remember to put in zeros as needed.

a

$$5 \overline{) 5 \quad 1 \quad 5}$$

b

$$3 \overline{) 6 \quad 6 \quad 9}$$

c

$$9 \overline{) 9 \quad 2 \quad 7}$$

d

$$4 \overline{) 8 \quad 0 \quad 4}$$

e

$$4 \overline{) 8 \quad 1 \quad 2}$$

## Task 3 - Extra Practice

[Click here to hear instructions](#)

Complete in your exercise book. You can use a calculator to check your answer is correct. Use a red pen to mark your work.

### Short division

Copy these into your book and solve them using the bus stop method.

1.  $315 \div 5 =$

2.  $288 \div 3 =$

3.  $684 \div 2 =$

4.  $528 \div 4 =$

5.  $717 \div 3 =$

6.  $472 \div 4 =$

7.  $968 \div 8 =$

8.  $904 \div 2 =$

9.  $765 \div 5 =$

10.  $895 \div 5 =$



Click here to  
hear  
instructions

## Extension

Complete an activity on Mathletics.



## Break 2

Create a new backyard game.  
You can create an obstacle course or a game using a ball.



# PDH - Nutrition

with Miss Strode





# What does the body require in order to remain healthy?

In our lesson today, we are going to look at some of the things are body needs in order to stay healthy.

We need to eat **healthy foods** and **drink plenty of water**. We also need to do **lots of exercise**, **get enough sleep** and **keep ourselves clean**. Watch the [video](#) to learn more about food groups and what to put on our plates.





# This is what a healthy plate looks like -

Eat fruits of all colors! Aim to eat whole fruits and limit fruit juice.



Eat vegetables with a variety of colors too! Eat mostly non-starchy vegetables.

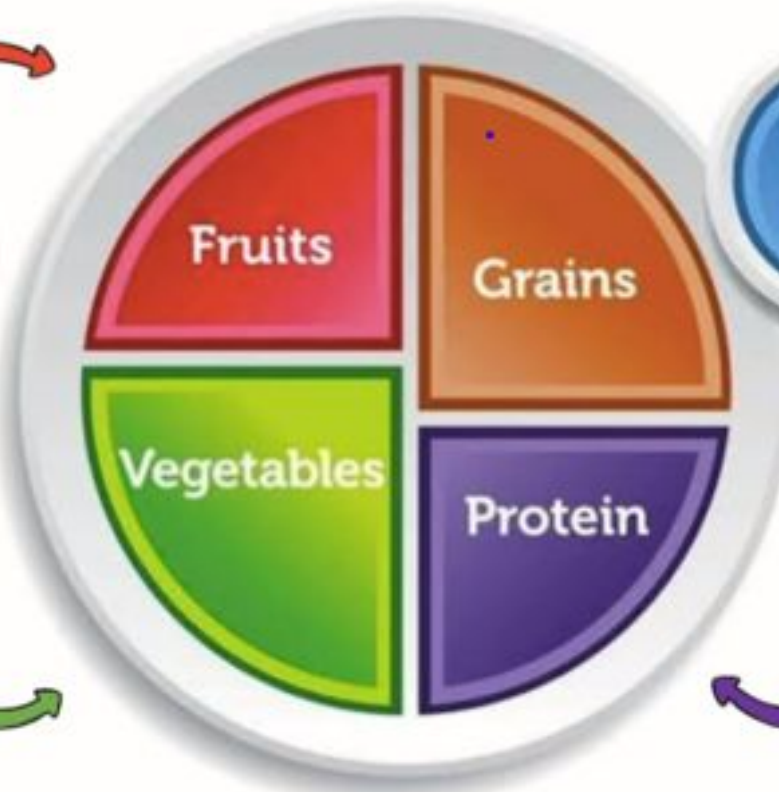

Aim for skim or 1%



Dairy

Make half your grains whole grains!



Protein the size of your palm is all you need for each meal. Choose lean options.





# What food does the body require to be healthy?

## To eat a healthy diet:

1. Eat enough foods from each of the five food groups every day.
2. Choose different varieties of foods from within each of the five food groups from day to day, week to week and at different times of the year.  
  
Eat plenty of plant foods (bread, cereal, rice, pasta, noodles, vegetables, legumes and fruit), moderate amounts of animal foods (milk, yoghurt, cheese, meat, fish, poultry and eggs) and small amounts of the extra foods as well as margarine and oils.
4. Drink plenty of water.



**Test your knowledge of the five food groups by playing [this Kahoot](#). Please type in your first name and the first letter of last name. All students in Stage 3 will be versing each other in this challenge. The results will be published in your Google Classroom tomorrow morning.**  
**[Press here to play](#)**





# EAT WELL GUIDE

Use the guide to help you achieve a healthy, balanced diet.





Play the following game by clicking [here](#)

MUTE

# Welcome to the MyPlate Match Game

Test what you know about the food groups.

START GAME











# Activity: Plan 5 healthy dinners

Create 5 days of healthy dinner meals that you would enjoy. Create a table like the one below, in your exercise book. Take a photo of your work and upload this the Thursday Task on Google Classroom.

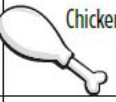
My 5-Day Dinner Menu Planner

	SAMPLE	DAY 1	DAY 2	DAY 3	DAY 4	DAY 5
FRUITS	 Peach					
VEGETABLES	 Spinach					
GRAINS	 Whole-wheat roll					
PROTEIN	 Chicken					
DAIRY	 Milk					

# Reflection for Thursday's lessons

Complete this in your exercise book. You can take a photo and upload to Google Classroom. We love reading your reflections.

Mrs Freney and Mrs Roda.

[Click here to hear instructions](#)

## Reflection Points:

- 1 thing you liked and why
- 1 thing you found hard
- 1 thing you'd like more of



**HAVE A  
NICE DAY**

# Kearns PS Online Learning – Stage

Daily Lessons





# Friday

Student resources



# English

Student resources



# Listen

Click here to  
hear  
instructions

[Listen to the Squiz Kids Podcast](#) - Click here

**Write a 3-2-1 response in the Google Classroom thread.**

**Write 3 things you learnt, 2 questions you have and one opinion that you have. You can respond to your classmates as well.**

**This is a compulsory task meaning that we expect a 3-2-1 response from everyone today.**

**SQUIZ  
KIDS**



Click here to  
hear  
instructions

# Media Arts/Literacy

## Lockdown Mundane Task Documentary

With their permission, film a member of your family or yourself performing a mundane, everyday task such as hanging the washing, brushing your teeth, doing the dishes.

Then write and record an audio commentary to go with the vision, as though you are the narrator of a wildlife documentary.

Watch the **first five minutes** of [this documentary](#) narrated by David Attenborough to inspire you. An example can be found by clicking on the link below:

[David Attenborough Documentary](#)

# Task

## Lockdown Mundane Task Documentary

**EXAMPLE:** At about 8am every day the species known as Lockdownius Boredess complete the same fascinating ritual. They eat their Weetbix, wash the dishes and complain about who is going to dry them and pack them away...

You can use humour and have a lot of fun with this one.

### Rules:

1. You need to film a **one minute** segment
2. You need to narrate (explain what is happening) in the video.
3. Upload your one minute video to the Google Classroom Friday W5  
ASSIGNMENT. We are looking forward to seeing what you come up with.

# Break 1

## Scissor Paper Rock

This is a 2-person game.

1. On the count of three, players pick their position with their hands: Rock- hand in a fist, Paper- hand flat, paper down, Scissors- extend the first two fingers and hold them apart.

2. The winner of the round is determined by the items formed:

- Rock crushes scissors
- Scissors cuts paper
- Paper covers rock

3. Conduct 3-5 rounds of the game.



# Mathematics

Student resources





# Warm Up

## Division

Click here to  
hear  
instructions

Set a timer for 10 minutes and play [Flying High Race - Division](#) to warm up.



## Written methods – short division with remainders

Sometimes numbers don't divide evenly. The amount left over is called the **remainder**.

$$\begin{array}{r} 105 \text{ r } 2 \\ 5 \overline{) 527} \end{array}$$

Look at 527 divided by 5.

500 divided by 5 is 100.

27 divided by 5 is 5 with 2 left over (this is the remainder).

This can be written as r 2.

$$527 \div 5 = 105 \text{ r } 2.$$

$$28 \div 5 = 5 \text{ r } 3$$

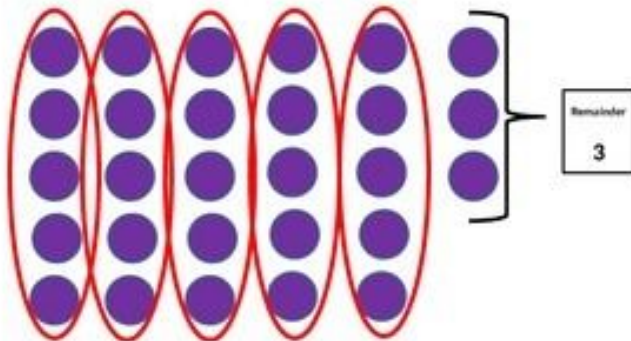

# Task 1

Complete in your exercise book. You can use a calculator to check if your answer is correct.

Use a red pen to mark your work. When you have finished, take a picture of your work and upload it to the “Friday W5 Mathematics Activity” doc on Google Classroom.

Divide these 2 digit numbers. Each problem will have a remainder.

a

$$9 \overline{) 75r}$$

b

$$4 \overline{) 47r}$$

c

$$6 \overline{) 38r}$$

d

$$5 \overline{) 63r}$$

e

$$4 \overline{) 49r}$$

f

$$6 \overline{) 62r}$$

## Task 2

Complete in your exercise book. You can use a calculator to check if your answer is correct. Use a red pen to mark your work.

Divide these 3 digit numbers. Each problem will have a remainder.

a

$$5 \overline{) 557} \quad r$$

b

$$3 \overline{) 661} \quad r$$

c

$$4 \overline{) 481} \quad r$$

d

$$9 \overline{) 994} \quad r$$

e

$$4 \overline{) 845} \quad r$$

f

$$6 \overline{) 638} \quad r$$

## Task 3

Complete in your exercise book.

Solve these problems:

- a Giovanni's Nonna has given him a bag of gold coins to share among him and his two sisters. There are 47 gold coins altogether. How many does each child get if they're shared evenly? How would you suggest they deal with the remainder?

- 
- b You have 59 jubes to add to party bags. Each bag gets 5 jubes. How many full party bags can you make?





Click here to  
hear  
instructions

## Extension

Complete an activity on Mathletics.



## Break 2

Helping with some household tasks such as making your bed, hanging clothes up to dry or washing the dishes.



# PDHPE - Physical Education

Student resources

Click here to  
hear  
instructions

# Dance Home Learning Program

Click the link and follow along  
with JROD and his awesome  
dance moves!

[Dance Lesson 3 Click Here](#)

# Reflection for Friday's lessons

**Complete this in your exercise book. You can take a photo and upload to Google Classroom. We love reading your reflections.**

**Mrs Freney and Mrs Roda.**

**Click here to  
hear  
instructions**

## Reflection Points:

- 1 thing you liked and why
- 1 thing you found hard
- 1 thing you'd like more of

